

INCA  
OFFICE

NAMI  
OFFICE

**4MARIANI**



INCA  
OFFICE

**4MARIANI**







## Inca executive office

Il progetto Inca nasce con l'intento di diventare per i 4Mariani una collezione ufficio leggera, semplice nelle linee e con un tratto fortemente riconoscibile. Tutto ruota intorno al tema dell'intersezione di volumi semplici, parallelepipedi che fusi tra loro delineano i vari elementi della collezione. Partendo dal "piede" in legno laccato che rappresenta trait d'union tra scrivania direzionale e tavoli, arrivando ai mobili contenitori fino alle maniglie.

The Inca model is born with the intention of becoming a light office collection for 4Mariani, simple in its lines and with a highly recognizable feature. Everything moves around the theme of the intersection of simple volumes, parallelepipeds that fused together outline the various elements of the collection. Starting from the "foot" in lacquered wood that represents the link between executive desk and tables, to the storage cabinets up to the handles.



NEL DETTAGLIO SCATOLA  
PORTAPRESE CON ROTAZIONE  
A SCOMPARSA INTEGRATA NELL  
ELEMENTO LACCATO A FIANCO  
DEL MOBILE ALLUNGO.

IN DETAIL, SOCKET BOX WITH  
RETRACTABLE ROTATION  
INTEGRATED IN THE LACQUERED  
ELEMENT NEXT TO THE  
SIDEBOARD CABINET.

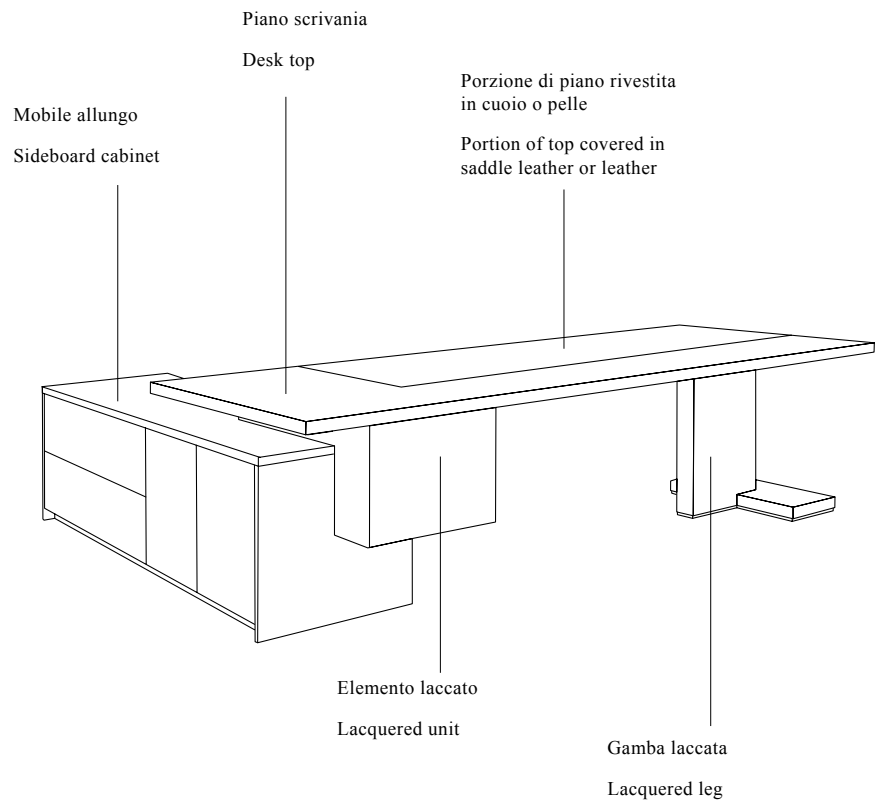

NELLE IMMAGINI DI DETTAGLIO  
SI EVIDENZIA L'ACCOSTAMENTO  
DEI MATERIALI CHE PREVEDE LA  
COMBINAZIONE DI ESSENZA, PELLE  
O CUOIO E LACCATURA.

THE DETAIL IMAGES SHOW THE  
COMBINATION OF MATERIALS WHICH  
PROVIDES FOR THE MIX OF WOOD,  
SADDLE LEATHER OR LEATHER AND  
LACQUERING.



# Technicals Inca executive office

PIANI IN CUIOIO O PELLE - SADDLE LEATHER OR LEATHER TOPS

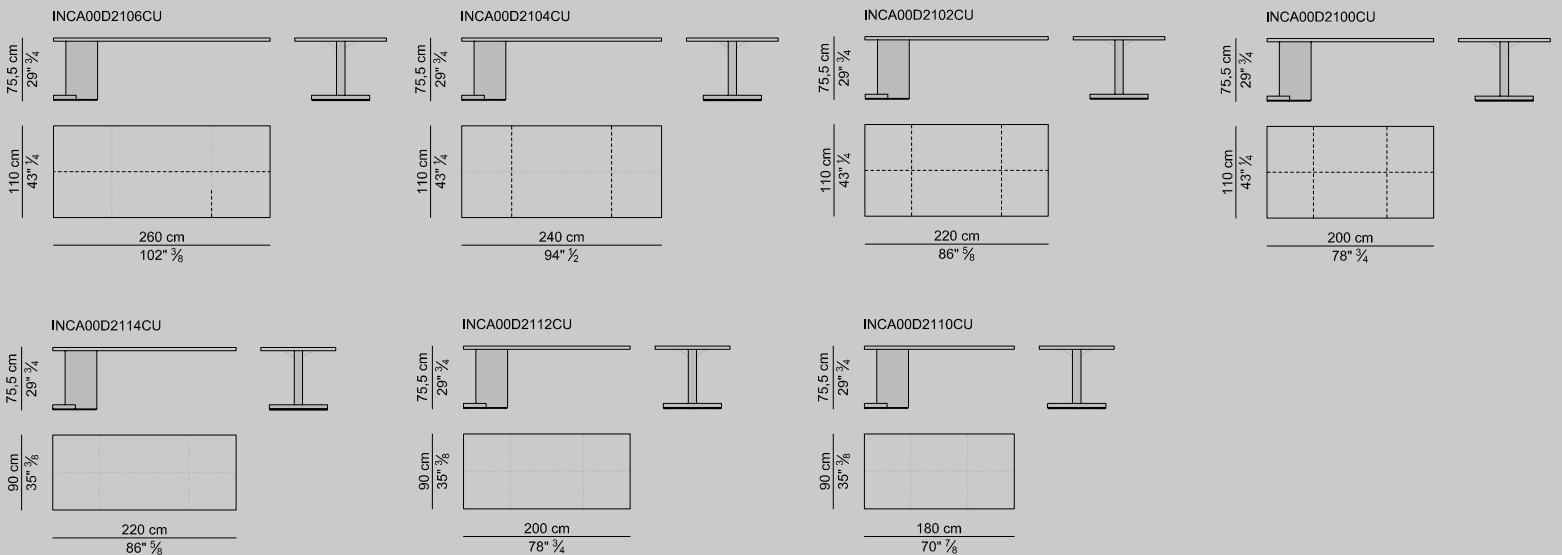



PIANI SCRIVANIA IN ESSENZA O MELAMINICO - VENEER OR MELAMINE TOPS

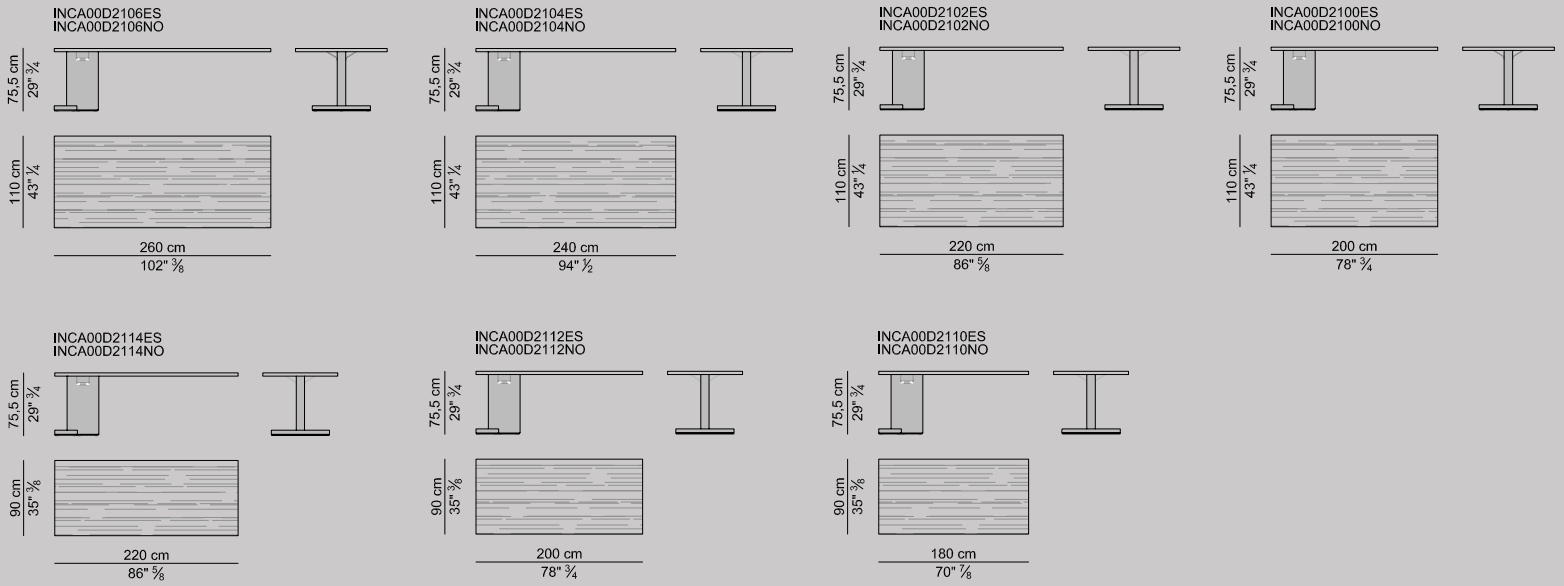

PIANI SCRIVANIA IN ESSENZA/MELAMINICO/CUOIO/PELLE - VENEER/MELAMINE/SADDLE LEATHER/LEATHER TOPS

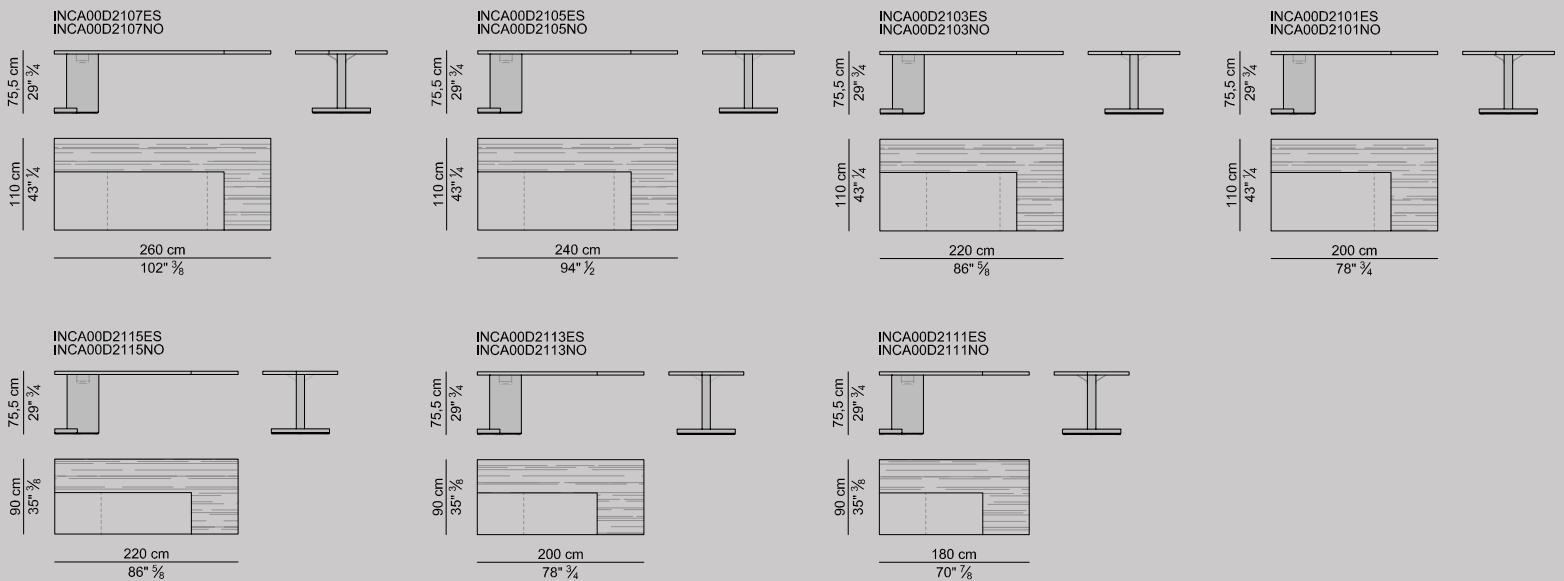

GAMBA - LEG

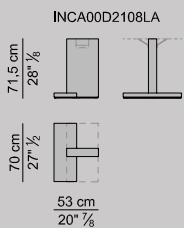

MODESTY PANEL



I piani sono realizzati con pannelli di particelle di legno impiallacciati o rivestiti in cuoio o in pelle, oppure in nobilitato. Disponibili anche nella versione parzialmente rivestita in cuoio o pelle. The tops are made with particleboard panels veneered or covered in saddle leather or in soft leather or otherwise in melamine coated panels. Available also in the version partially covered in saddle leather or leather.



# Technicals Inca executive office

MOBILI ALLUNGO CON PIANO IN CUIO O PELLE - SIDEBORD CABINETS WITH TOP IN SADDLE LEATHER OR LEATHER

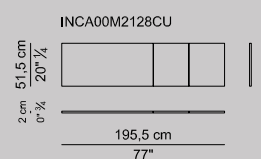
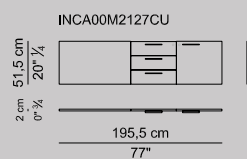
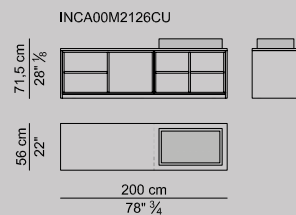
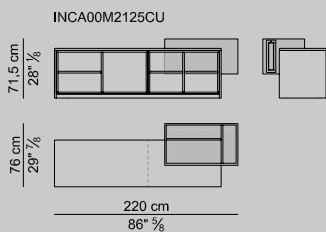

MOBILI ALLUNGO CON PIANO IN ESSENZA O MELAMINICO - SIDEBORD CABINETS WITH TOP IN VENEER OR MELAMINE

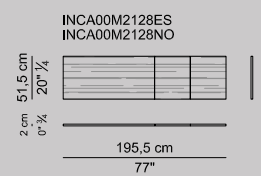
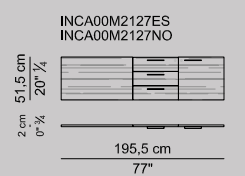
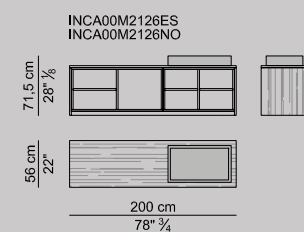
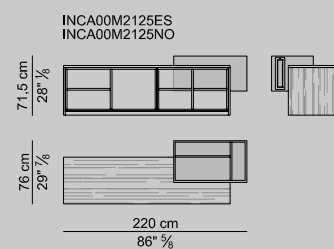



CASSETTIERE FISSE - FIXED PEDESTALS

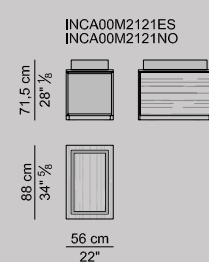
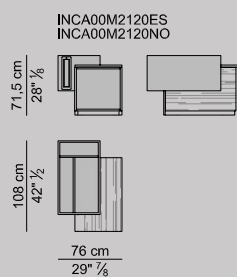
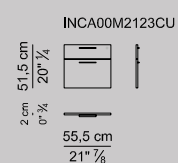
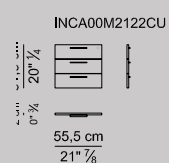
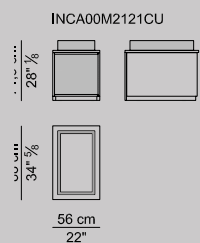
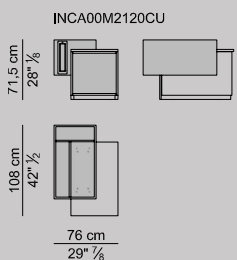



A DESTRA ABSTRACT LEATHER,  
COLLEZIONE DI ARTWORK  
DISEGNATA DA DE GRANDIS STUDIO.  
COMPOSTI DA SUPERFICI IN RILIEVO  
IN CUIO REALIZZATE A MANO.

ON THE RIGHT ABSTRACT LEATHER,  
ARTWORK COLLECTION DESIGNED  
BY DE GRANDIS STUDIO. MADE OF  
HANDMADE SADDLE LEATHER RELIEF  
SHAPES.

---

## Inca asymmetrical cabinet

Mobile asimmetrico Inca in essenza tipo ebano con top, ante sporgenti e maniglie laccati grigio antracite; interno in nobilitato nero.

Inca asymmetrical cabinet in ebony type wood with top, protruding doors and handles charcoal grey lacquered; interior in black melamine.





## Technicals Inca asymmetrical cabinet

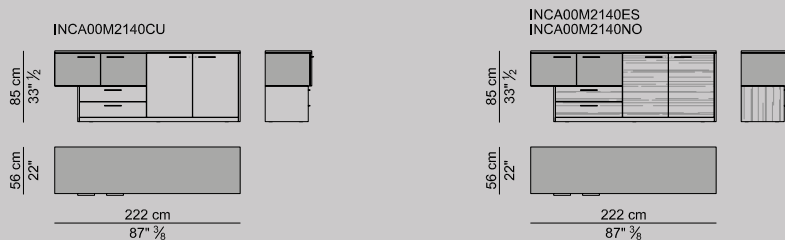

Strutture in nobilitato nero. Top, fianchi e frontali di cassetti ed ante sono realizzati in nobilitato e disponibili impiallacciati, in melaminico o rivestiti in cuoio o pelle. Cassetti in multistrato laccati neri. Ripiani interni in nobilitato nero. Maniglie in profilato di alluminio verniciato grigio antracite. Frame in black melamine coated panels. Top, sides, fronts of drawers and doors are made in melamine coated panels and are available veneered or in melamine or covered in saddle leather or in soft leather. Drawer's frame in black lacquered plywood. Handles in aluminum profile charcoal grey painted.



# Technicals Inca work chair

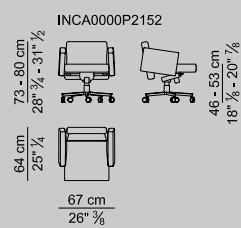
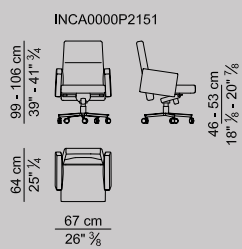
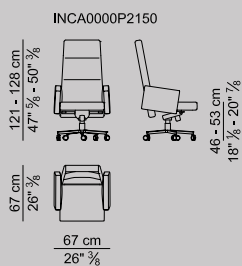

Con la stessa logica compositiva nascono le poltrone Inca, disegnate per accostamento di volumi semplici e sviluppate in tre misure.  
The Inca armchairs are born with the same compositional logic, designed by combining simple volumes and developed in three sizes.







La boiserie del modello De Symetria è disponibile di serie in moduli standard con larghezza cm 100 e altezza cm. 240. Per questi moduli sono disponibili di serie a scelta del cliente dei profili orizzontali in alluminio sia con funzione estetica che con funzione reggi mensole che possono essere posizionati ad una altezza da pavimento di cm. 60, 120 o 180. Sono invece necessari il profilo terminale inferiore, e quello superiore in alluminio. Naturalmente la boiserie è disponibile anche in pannelli con altezza e larghezza non di serie adeguati alle dimensioni dell'ambiente del cliente.

The De Symetria wall paneling is available with standard modules of width cm 100 and height cm 240. Horizontal profiles in aluminum – with ornamental purpose as well as function of shelf holder – are available at client choice and can be set at cm 60, 120 or 180 from floor. A terminal lower profile and a terminal upper profile in aluminum is necessary for the 240 cm height wall panelling. Obviously the wall paneling is also available with customized panels with non standard height and width in accordance with the dimensions of client's walls.



A SINISTRA DETTAGLIO DELLA  
MENSOLA IN CUOIO  
ON THE LEFT SHELF DETAIL IN  
SADDLE LEATHER

NELLA PAGINA SEGUENTE DETTAGLIO  
DEL PIANO DEL TAVOLO INCA IN  
ESSENZA DI TIPO EBANO E DELLA  
GAMBA LACCATA IN COLORE GRIGIO  
ANTRACITE.  
ON THE NEXT PAGE INCA TABLE TOP  
DETAIL IN EBONY TYPE VENEER AND  
LEG LACQUERED IN CHARCOAL GREY  
COLOR.





# Technicals Inca executive office

TAVOLI PIANO IN CUIOIO - SADDLE LEATHER TOP TABLES

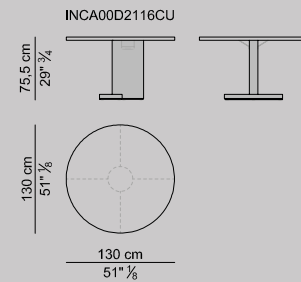
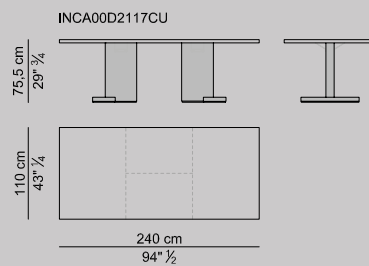
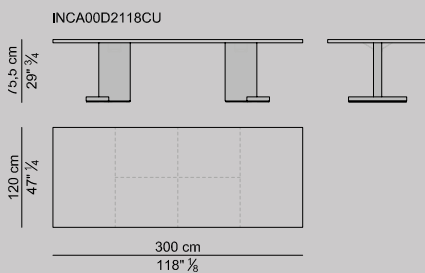

Essenze disponibili di serie: tipo ebano e frassino laccato in tinta con qualsiasi colore di pelle delle categorie PS e PF. Melaminici disponibili in collezione. Altre finiture su richiesta.

Standard wood veneers available: ebony type wood and ash wood lacquered to match any leather color of PS and PF categories. Melamine finishes available on collection. Other finishes available only on request.

TAVOLI CON PIANO IN ESSENZA O MELAMINICO - VENEER OR MELAMINE TOP TABLES

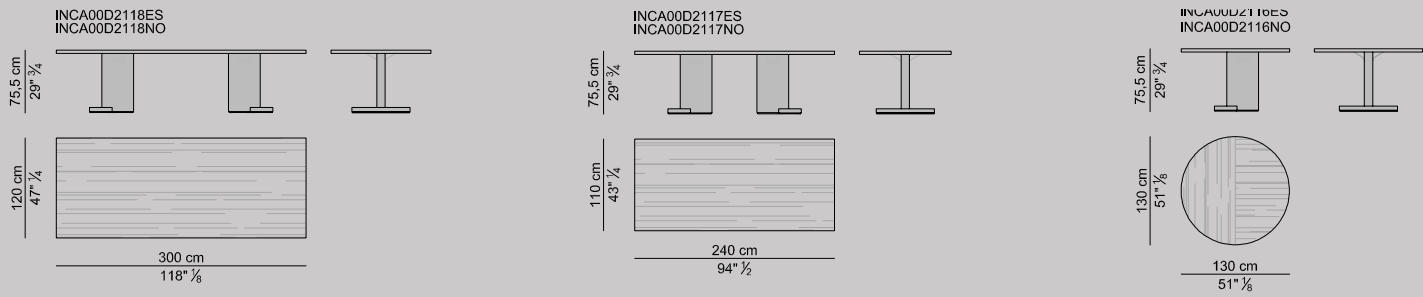

MOBILI DI SERVIZIO CON PIANO SOLLEVABILE ELETTRICAMENTE IN CUIO/PELLE -  
ELECTRICALLY LIFTABLE SADDLE LEATHER OR LEATHER TOP SERVICE CABINET

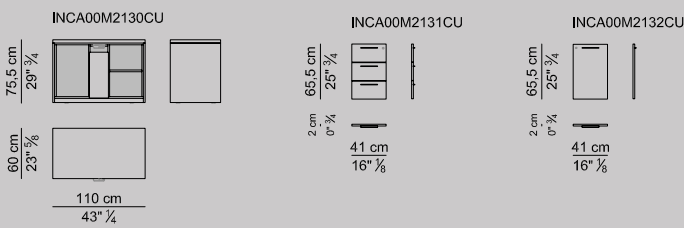

MOBILI DI SERVIZIO CON PIANO SOLLEVABILE ELETTRICAMENTE IN ESSENZA O  
MELAMINICO - ELECTRICALLY LIFTABLE VENEER OR MELAMINE TOP SERVICE CABINET



MOBILI CON PIANO IN CUIO O PELLE -  
SADDLE LEATHER OR LEATHER TOP LOW CABINETS

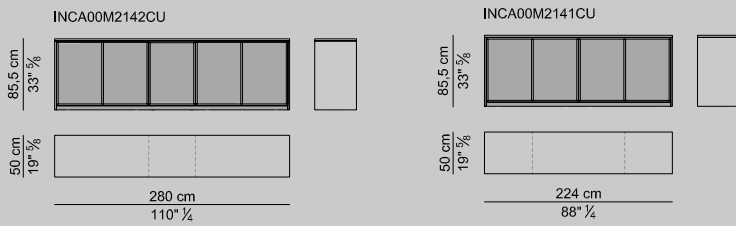

MOBILI CON PIANO IN ESSENZA O MELAMINICO -  
VENEER OR MELAMINE TOP LOW CABINETS

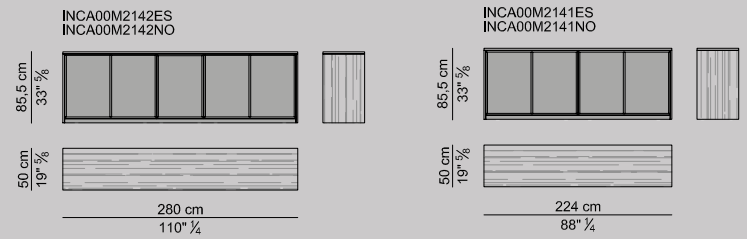





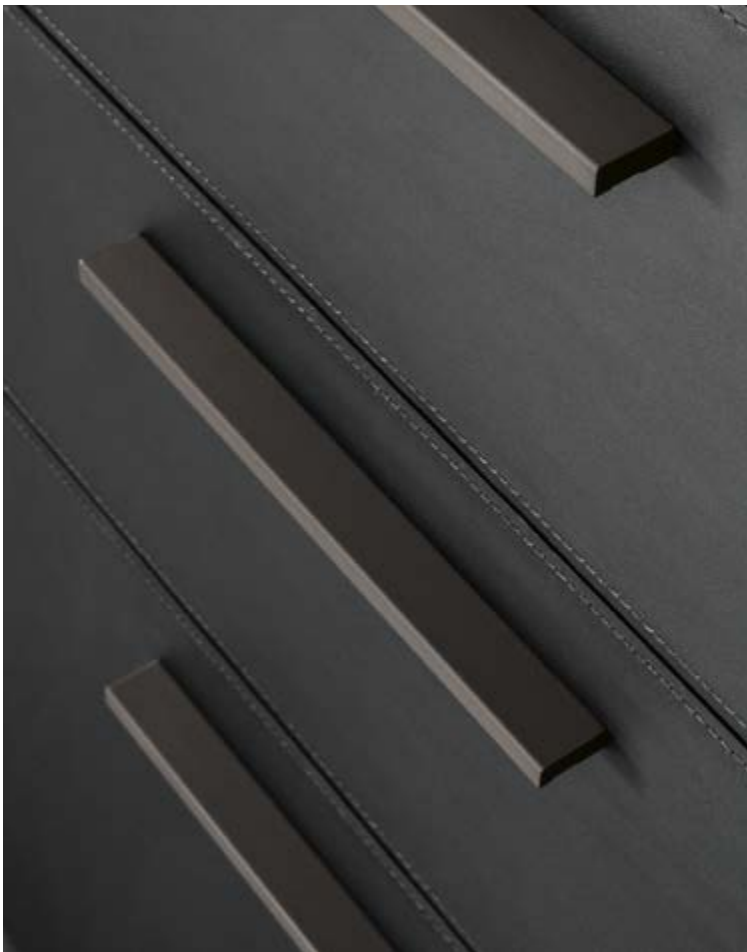

## Inca executive office

Scrivania Inca con piano in frassino tinto grafite e cuoio Privilege nero CF 207, gamba e struttura laccata in grigio antracite, cassettera fissa in frassino tinto grafite con maniglie in alluminio verniciato grigio antracite.

Inca desk with graphite stained ash and saddle leather Privilege CF 207 top, leg lacquered in charcoal grey color, fixed pedestals in graphite stained ash with handles in aluminum profile painted in charcoal grey color.





NEL DETTAGLIO SISTEMA DI RICARICA WIRELESS POSIZIONATO AL DI SOTTO DEL PIANO IN CORRISPONDENZA DELL'IMPRESSIONE NEL CUOIO A CERCHI CONCENTRICI.

WIRELESS CHARGING SYSTEM POSITIONED BELOW THE TOP IN CORRESPONDENCE WITH THE IMPRESSION IN THE LEATHER WITH CONCENTRIC CIRCLES.

NELLE IMMAGINI DI DETTAGLIO SI EVIDENZIA L'ACCOSTAMENTO DEI MATERIALI CHE PREVEDE LA COMBINAZIONE DI ESSENZA, PELLE O CUOIO E LACCATURA.

THE DETAIL IMAGES SHOW THE COMBINATION OF MATERIALS WHICH PROVIDES FOR THE MIX OF WOOD, SADDLE LEATHER OR LEATHER AND LACQUERING.

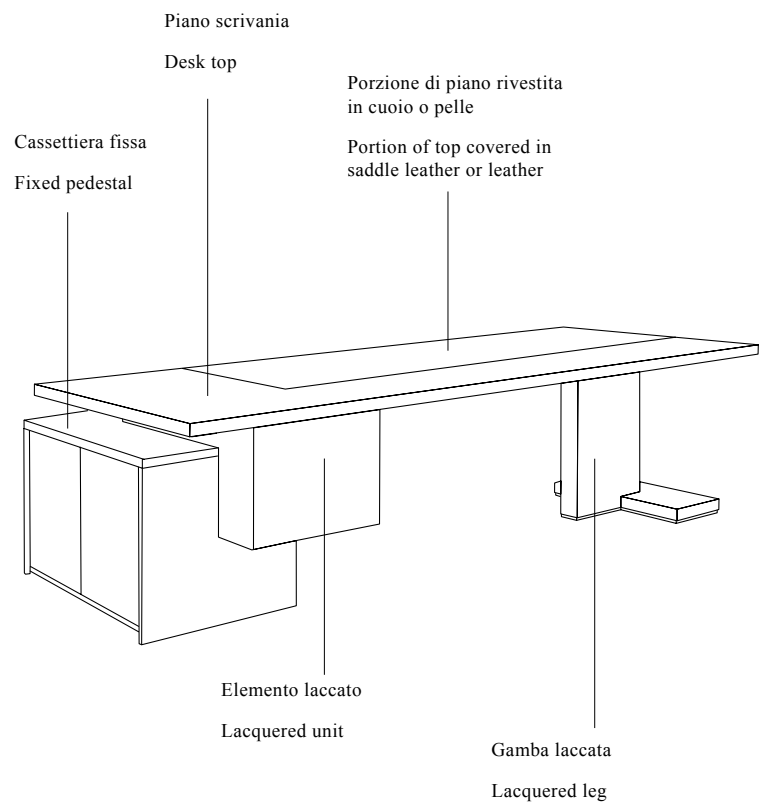



## Inca service cabinet

Mobile di servizio con top regolabile in altezza elettricamente. Ideale per lavorare in posizione eretta.

Service cabinet with electrically height-adjustable top. Ideal for working in an upright position.



Mobile simmetrico Inca con piano in frassino tinto grafite, interno in nobilitato nero, ante in frassino tinto grafite e frontali cassetti in cuoio CF 207 nero con maniglie in alluminio verniciato grigio antracite.

Inca symmetrical cabinet with graphite stained ash top, interior in black melamine, graphite stained ash doors and fronts of drawers in black saddle leather CF 207 with charcoal grey color painted aluminum handles.



LA COLLEZIONE PABLO È CARATTERIZZATA DA UN SEGNO GRAFICO ESSENZIALE E DA TRATTI MINIMALI CHE RESTITUISCONO UNA GRANDE ADATTABILITÀ ALLE PIÙ DIVERSE ESIGENZE DI ARREDO PER LA CASA, L'UFFICIO E IL CONTRACT.

THE PABLO COLLECTION IS CHARACTERIZED BY AN ESSENTIAL GRAPHIC DESIGN AND MINIMAL FEATURES THAT GIVE GREAT ADAPTABILITY TO THE MOST DIFFERENT FURNISHING NEEDS FOR THE HOME, OFFICE AND CONTRACT.





# Technicals Pablo sofa and armchairs

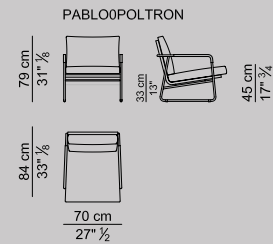
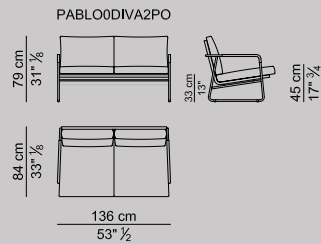
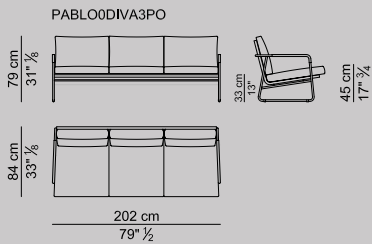

La struttura della seduta Pablo è in multistrato curvato imbottito, i cuscini di seduta e di schienale sono rivestiti in pelle o in tessuto mentre i braccioli, sono impreziositi con un decoro di cuoio intrecciato in colore nero o rosso bulgaro. Tra dettagli ricercati e design contemporaneo, s'intesse così un dialogo serrato tra funzionalità, eleganza e qualità.

The Pablo seat frame is in curved plywood padded, the seat and back cushions are covered in leather or fabric while the armrests are embellished with a black or red woven saddle leather straps decoration. Between refined details and contemporary design, a close dialogue between functionality, elegance and quality is interwoven.



# Technicals Papier coffee tables

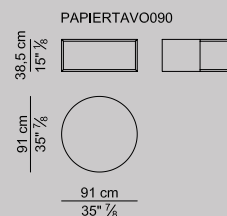
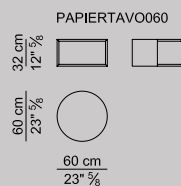
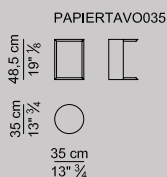

Papier è una collezione di complementi di arredo caratterizzata da essenzialità e leggerezza, ottenute grazie all'utilizzo di materiali e tecniche di lavorazione esclusivi. Come fogli di carta impalpabili i lembi di cuoio si modellano perfettamente sulle forme del legno, dalle superfici piane alle curvature degli angoli.

Papier is a collection of furnishings complements characterized by essentiality and lightness, obtained thanks to the use of materials and techniques of exclusive production. As very fine sheets of papers, the edges of saddle leather model themselves perfectly to the shapes of the wood, from the flat surfaces to the bending of the corners.









# Technicals Inca table

TAVOLI PIANO IN CUIO - SADDLE LEATHER TOP TABLES

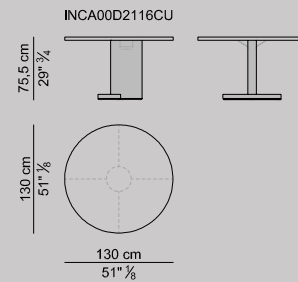
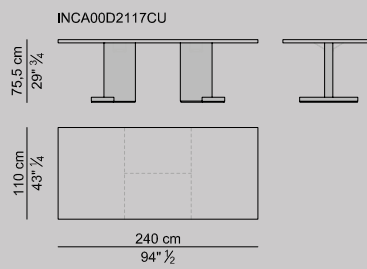
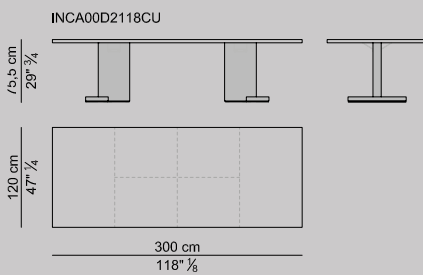

TAVOLI CON PIANO IN ESSENZA O MELAMINICO - VENEER OR MELAMINE TOP TABLES

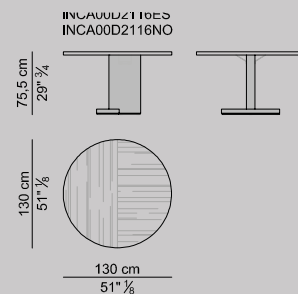
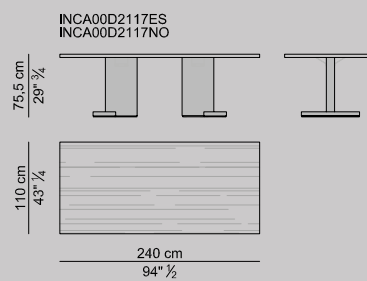
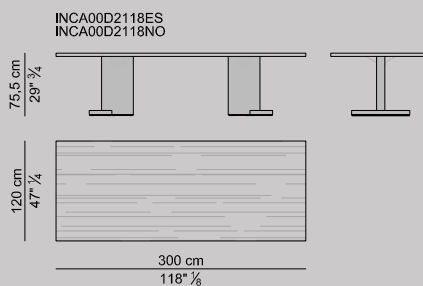



# Technicals Inca work chair

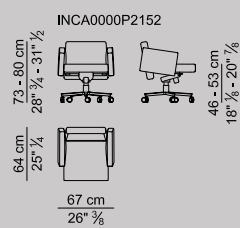
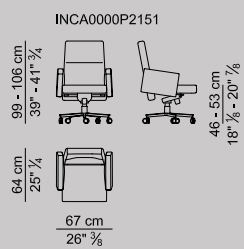
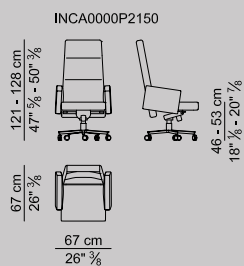

Con la stessa logica compositiva nascono le poltrone Inca, disegnate per accostamento di volumi semplici e sviluppate in tre misure.  
The Inca armchairs are born with the same compositional logic, designed by combining simple volumes and developed in three sizes.







# Inca executive office

MELAMINICI DISPONIBILI - MELAMINE FINISHINGS AVAILABLE

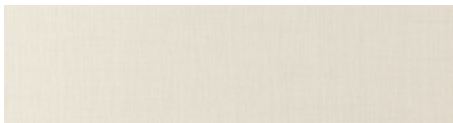

Melaminico Lino FA 41 . Linen Melamine FA 41



Melaminico Rovere Bianco LK 84  
White Oak Melamine LK 84



Melaminico Noce Chiaro LM 01  
Light Walnut Melamine LM01



Melaminico Noce Canaletto LM 05  
Black Walnut Melamine LM 05



Melaminico Rovere Grigio LG 18  
Grey Oak Melamine LG18



Melaminico Rovere Spessart LM 76  
Spessart Oak Melamine LM 76

Scrivania Inca con piano e struttura dell'allungo in nobilitato noce canaletto LM05, con ante e frontali dei cassetti in cuoio Privilege CF 206; gamba laccata e maniglie in alluminio verniciate entrambe in colore grigio antracite.

Inca desk with top and sideboard structure in LM05 Black walnut melamine, with doors and drawer fronts in Privilege CF 206 saddle leather; lacquered leg and aluminum handles both painted in charcoal grey colour.



NEL DETTAGLIO ABBINAMENTO NOBILITATO NOCE CANALETTO LM05 CON CUIO GRIGIO ANTRACITE CF 206 E CUCITURE A VISTA.

ON THE DETAIL, COMBINATION OF BLACK WALNUT MELAMINE LM05 WITH ANTHRACITE GRAY SADDLE LEATHER CF 206 AND VISIBLE STITCHING.

ANTE E CASSETTI DOTATI DI SERRATURA PER DISPORRE AL SICURO OGGETTI E DOCUMENTI.

DOORS AND DRAWERS EQUIPPED WITH LOCKS TO SAFELY DISPOSE OBJECTS AND DOCUMENTS.

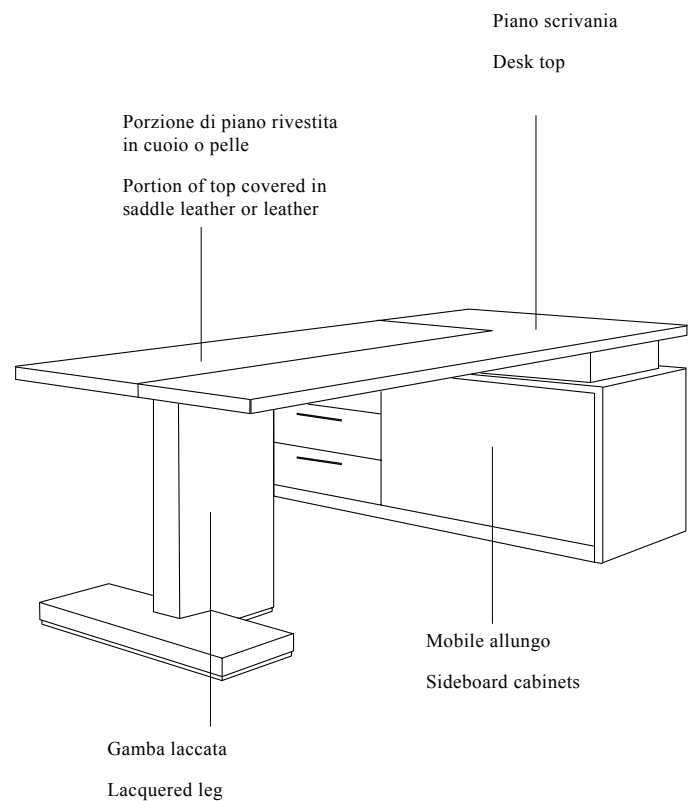

Mobile allungo Inca in nobilitato noce canaletto LM05, con ante e frontali dei cassetti in cuoio Privilege CF 206 dotati di serratura e chiave per archiviare documenti e oggetti. Interno in nobilitato nero.

Inca sideboard cabinet with top in LM05 Black walnut melamine, with doors and drawer fronts in Privilege CF 206 saddle leather equipped with locks to archive documents and objects. Interior in black melamine.







NAMI  
OFFICE



---

## Nami desk

La struttura sinuosa del desk Nami è espressione di una ricerca della forma armoniosa, un'onda capace di fare da contrappunto alle forme più rigorose degli spazi interni. Il contrasto tra i materiali, cuoio ed essenza, sottolinea le forme curvilinee e le proporzioni eleganti. Questo desk pensato per l'home office può arrivare a dimensioni più generose per entrare a pieno titolo nel mondo ufficio.

The sinuous frame of the Nami desk is the expression of a research for the harmonious form, a wave capable of acting as a counterpoint to the more rigorous forms of the interior spaces. The contrast between the materials, leather and wood, emphasizes the curvilinear shapes and elegant proportions. This desk designed for the home office can reach bigger dimensions to fully enter into the office world.





## Nami desk

Nami: desk con struttura in pannello multistrato di faggio curvato in stampo e rivestito in cuoio; il pannello di cortesia ed il cassetto sono in pannello di particelle di legno impiallacciato in essenza di noce canaletto fiammato. Vano interno impiallacciato in frassino tinto grafite. Disponibile con uno o due cassetti posti ai lati del desk. A sinistra dettaglio sul frontale del cassetto che segue la curva del piano in cuoio. A destra dettaglio del piano in cuoio in corrispondenza della divisione del pannello frontale in essenza.

Nami: frame in beech plywood curved into a mould and covered in saddle leather; modesty panel and drawer in melamine coated panel veneered in veined black walnut wood. Internal compartment veneered in graphite stained ash wood. Available with one or two drawers placed on the sides of the desk. On the left, detail on the front of the drawer that follows the curve of the leather top. On the right, detail of the leather top in correspondence with the division of the front panel in wood.



DETTAGLIO DEL PIANO IN CUIO  
CON SPORTELLO PASSACAVI  
CHIUSO/APERTO CON PRESA  
ELETRICA, PRESA USB-B E USB-C

DETAIL OF THE LEATHER TOP  
WITH CLOSED / OPEN CABLE  
HOLE WITH ELECTRIC SOCKET,  
USB-B AND USB-C SOCKET

IL SISTEMA DI RICARICA WIRELESS  
POSIZIONATO AL DI SOTTO DEL  
PIANO IN CORRISPONDENZA  
DELL'IMPRESIONE NEL CUIO A  
CERCHI CONCENTRICI GARANTISCE  
MASSIMA FUNZIONALITA' E DESIGN.  
IL SENSORE RISULTA LA SOLUZIONE  
IDEALE PER RICARICARE I DISPOSITIVI IN  
MODALITA' WIRELESS, SENZA CAVI.

THE WIRELESS CHARGING SYSTEM  
POSITIONED BELOW THE TOP IN  
CORRESPONDENCE WITH THE  
IMPRESSION IN THE LEATHER WITH  
CONCENTRIC CIRCLES GUARANTEES  
MAXIMUM FUNCTIONALITY AND  
DESIGN. THE SENSOR IS THE IDEAL  
SOLUTION FOR CHARGING DEVICES IN  
WIRELESS MODE, WITHOUT CABLES.

Sportello passacavi con  
prese elettriche

Cable hatch with  
electrical sockets

Ricarica wireless  
Wireless charging

Piano in cuoio  
Saddle leather top

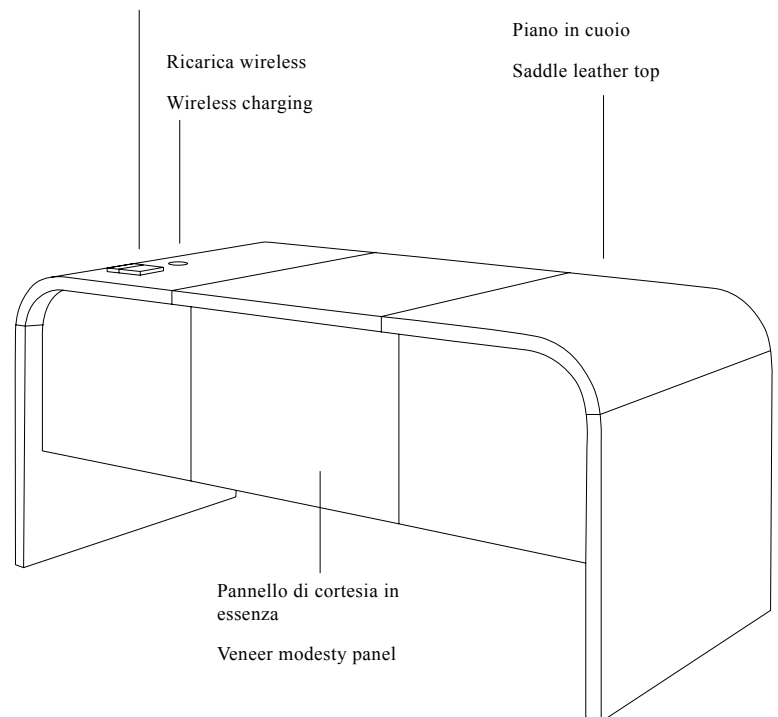

Nel dettaglio il cassetto destro del desk Nami: interno in frassino tinto grafite e frontale in essenza Noce Canaletto Fiammato. Le dimensioni del cassetto sono di 30x40 cm e possono contenere fogli di formato A4 e cancelleria.

In detail, the right drawer of the Nami desk: interior in graphite stained ash wood and front in veined black walnut wood with wax effect. The dimensions of the drawer are 30x40 cm and can hold A4 size sheets and stationery.







# Technicals Nami desk

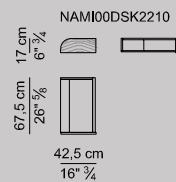
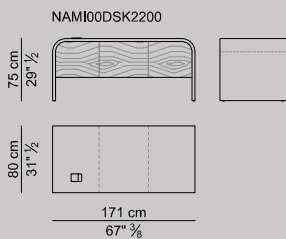

In base alla categoria di cuoio scelta, la misura dei diversi “tagli” dello stesso può variare in maniera sensibile. Essenze disponibili di serie: Noce canaletto fiammato effetto cera; interno cassetto in frassino tinto grafite.  
Depending on the category of saddle leather chosen, the size of its different “cuts” can vary significantly. Standard wood veneers available: Veined black walnut wood with wax effect; inside of the drawer in graphite stained ash wood.



# Technicals Silhouette workchairs and chairs

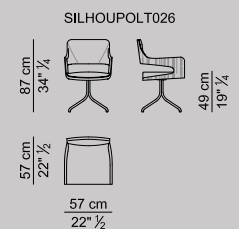
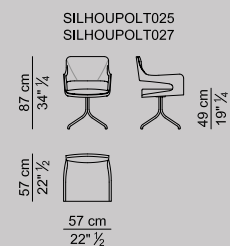
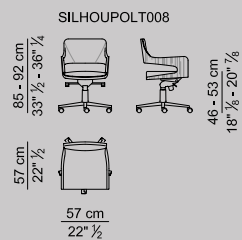
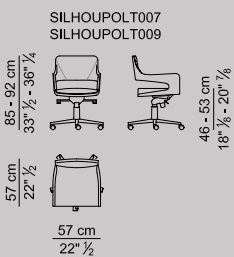
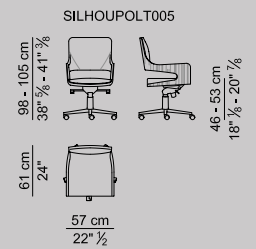
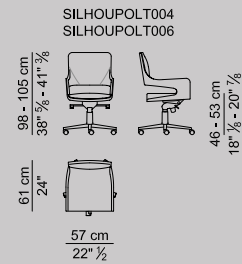
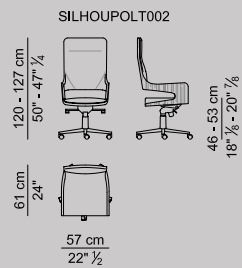
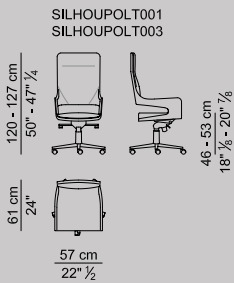







# Technicals

## Asso sofa

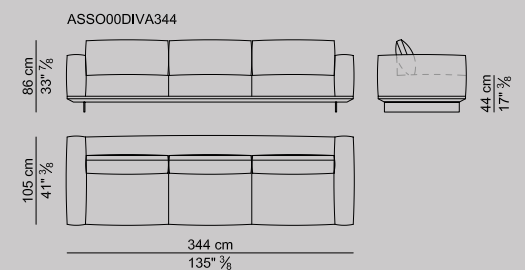
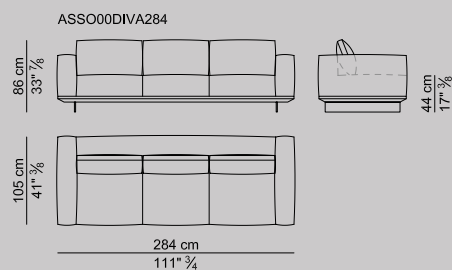
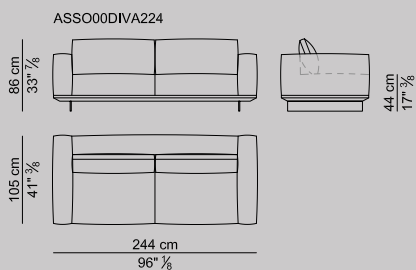
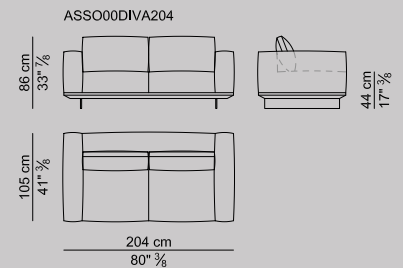
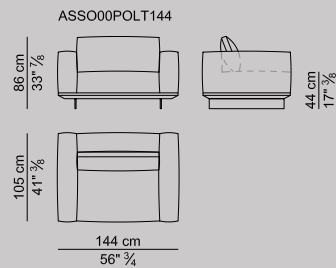
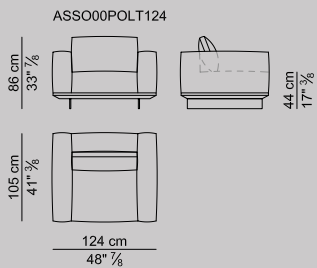

Divano Asso disponibile anche nella versione modulare angolare, con penisole, pouf, moduli libreria e tavolino.  
Asso sofa also available in the modular corner version, with peninsulas, ottomans, bookcase and low table units.



# Technicals Climbe coffee tables

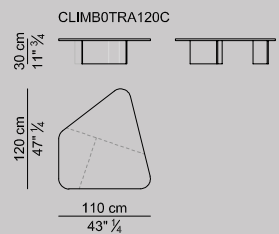
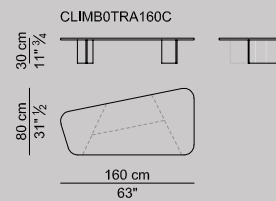
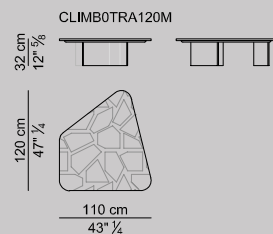
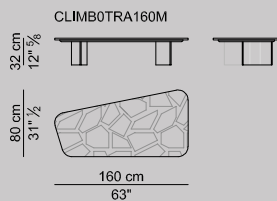
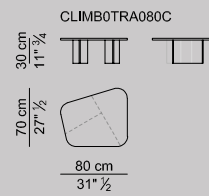
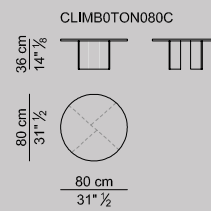
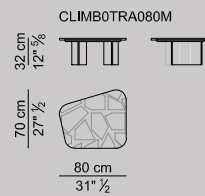
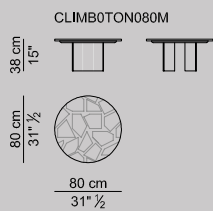
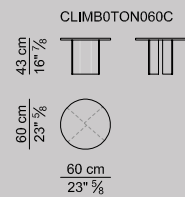
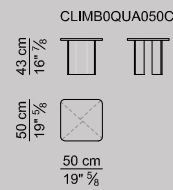
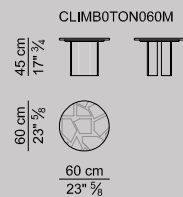
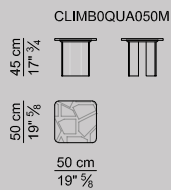

PELLE . LEATHER



Oltre 100 tipologie di pelle. More than 100 typologies of leathers.

CUOIO . SADDLE LEATHER



60 tipologie di cuoio. 60 typologies of saddle leathers



## ESSENZE . VENEERS



Tipo Rovere Naturale . Natural Oak type



Noce Canaletto Fiammato Tinto Grigio  
Grey Stained Veined Black Walnut Wood



Noce Canaletto Fiammato . Veined Black Walnut



Noce Biondo Rigato . Striped Blonde Walnut



Tipo Palissandro . Rosewood type



Eucalipto . Eucalyptus



Tipo Ebano . Ebony type



Ebano Macassar . Macassar Ebony



Tipo Rovere Moro . Dark Brown Oak type



Noce Canaletto Rigato . Striped Black Walnut



Frassino tinto grafite . Graphite Stained Ash



Tipo Rovere Titanio . Titanium Oak type

## MELAMINICI . MELAMINE FINISHINGS

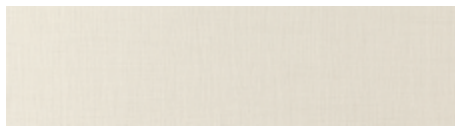

Melaminico Lino FA 41 . Linen Melamine FA 41



Melaminico Rovere Bianco LK 84  
White Oak Melamine LK 84



Melaminico Noce Chiaro LM 01  
Light Walnut Melamine LM01



Melaminico Noce Canaletto LM 05  
Black Walnut Melamine LM 05



Melaminico Rovere Grigio LG 18  
Grey Oak Melamine LG18



Melaminico Rovere Spessart LM 76  
Spessart Oak Melamine LM 76

COMPANY ART DIRECTION

Umberto Asnago

CATALOGUE ART DIRECTION

Lorenzo De Grandis Studio

STYLING

Cristina Corbetta

IMAGES

Massimo Spada

PRE-PRESS

Emmequadro

PRINT

Bellavite

COPYRIGHT

CR&S i4Mariani

2023

i4MARIANI S.R.L.

VIA S. ANTONIO 102/104  
22066 MARIANO COMENSE  
COMO, ITALY  
PH +39 031 746204  
FAX +39 031 749060  
INFO@I4MARIANI.IT  
WWW.I4MARIANI.COM

La descrizione e le immagini dei prodotti del presente catalogo sono puramente indicative e non possono essere considerate vincolati ai fini del loro utilizzo. i4Mariani si riserva di apportare ai prodotti le modifiche che ritiene più opportune, in qualsiasi momento e senza preavviso. Per ulteriori informazioni invitiamo a consultare il sito [www.i4mariani.com](http://www.i4mariani.com)

Descriptions and pictures of products included in this catalogue have an indicative value only and are not binding for products' use. i4Mariani reserves the right to modify their products without prior notification. For further technical information of the products, please go and see [www.i4mariani.com](http://www.i4mariani.com)